

EZ-ZONE™ ST Integrated Control Loop Makes Solving the Thermal Requirements of Your System Easy

Watlow's new EZ-ZONE™ ST integrated control loop solid state controller offers complete thermal system control in a single package solution. You get a PID temperature controller already connected to a high amperage solid state relay with the option of adding a properly sized heat sink, an over/under temperature limit, a shut-down power contactor, digital communications and a remote user interface in one complete and professionally engineered product. Your life just became a whole lot easier when it comes to solving the thermal requirements of your system.

Because the system is modular and scalable you only pay for what you need. You can stack the EZ-ZONE ST integrated thermal loop into multiple configurations giving you the flexibility to standardize on the product's platform to solve your wide range of application needs.

Features and Benefits

Back panel or DIN-rail mount

- Provides several mounting options

Compact package

- Reduces panel size

Touch-safe package

- Complies to IP2X which increases safety for user

±0.1 percent temperature accuracy

- Provides efficient and accurate temperature control

Agency approvals: UL®, CSA, CE, RoHS, W.E.E.E.

- Meets applications requiring agency approvals

EZ-ZONE ST P3T Armor Sealing System Remote User Interface (RUI)

- Complies to NEMA 4X, IP65 RUI
- Offers water and dust resistance, can be cleaned and washed down

Three-year warranty

- Demonstrates Watlow's reliability and product support

Off-the-shelf designed system solution

- Improves system reliability and termination reduction
- Reduces installation cost
- Eliminates compatibility headaches often encountered with using many different components and brands

Advanced controllability algorithms

- Offers TRU-TUNE™+ for meeting demanding controllability requirements

Profile capability

- Includes ramp and soak with four files and 40 total steps

Multiple U.S. and international patents pending.

UL® is a registered trademark of Underwriter's Laboratories Inc.
Modbus™ is a trademark of Schneider Automation Incorporated.



Features and Benefits (con't)

Solid state relay output

- Allows faster cycling, more precise control, increased heater life and energy efficiency

PID temperature control

- Provides accurate temperature control
- Allows single input/dual output
- Allows standard PID or advanced PID tuning algorithms

Optional 485 Modbus™ RTU communication

- Allows network connectivity to PC or PLC

Optional temperature limit

- Increases safety in under/overtemperature condition

Optional definite purpose mechanical contactor

- Enables circuit safety shut down driven by limit control or PID alarm output signal

Optional current monitoring feature

- Detects heater current flow and alarm indication of failed Solid State Relay (SSR) or heater zone

Optional Remote User Interface (RUI)

- Use one RUI for multiple zone solutions to save costs
- Fits in small places due to shallow panel depth
- Eliminates costs and complexity of having to bring all controller related wires to front panel area
- Enables use of multiple remote user interfaces to improve usability of system

Optional SSR heat sink

- Sized and engineered for specific applications
- Factory supplied heat sink provides UL® listed benefits

System diagnostics

- Provides continuous self-monitoring alerts when there is any system trouble to reduce maintenance and service costs

PC Software—EZ-ZONE ST configurator

- Wizard style configuration of controller settings
- On-line or off-line recipe editing



WATLOW

1241 Bundy Boulevard
Winona, Minnesota 55987-5580 USA
Phone: +1 (507) 454-5300
Fax: +1 (507) 452-4507
Internet: www.watlow.com
E-mail: info@watlow.com

WIN-EZST-0306

ISO 9001



Specifications

Line Voltage/Power

- 100 to 240V~(ac), +10/-15 percent; (85-264V~[ac]), 50/60Hz, ±5 percent
- 24V=(ac/dc), +10/-15 percent; 50/60Hz, ±5 percent
- 12VA maximum power consumption without mechanical contactor in system
- 50VA maximum power consumption with mechanical contactor used in system, 140VA if using external contactor
- Data retention upon power failure via nonvolatile memory

Environment

- -18 to 70°C (0 to 149°F) operating temperature
- -40 to 85°C (-40 to 185°F) storage temperature
- 0 to 90 percent RH, non-condensing

Accuracy

- Calibration accuracy and sensor conformity: ±0.1 percent of span, ±1°C @ the calibrated ambient temperature and rated line voltage
 - Types R, S, B; 0.2 percent
 - Type T below -50°C; 0.2 percent
- Calibration ambient temperature @ 25°C ±3°C (77°F ±5°F)
- Accuracy span: 540°C (1000°F) minimum
- Temperature stability: ±0.1°C/°C (±0.1°F/°F) rise in ambient maximum

Agency Approvals

- UL®, CSA, CE, IP65/NEMA 4X indoor use RUI, RoHS, W.E.E.E.
- Limit version features FM approval

Controller

- Microprocessor based user-selectable control modes
- PID module: Single universal input, 2 outputs
- Limit module: Single universal input, 2 outputs
- Two total additional digital input/outputs shared between PID and limit functions
- Control sampling rates: input = 10Hz, outputs = 10Hz
- Isolated EIA 485 Modbus™ RTU serial communications

Wiring Termination—Touch Safe Terminals

- Input, power and controller output terminals touch safe removable 12 to 22 AWG
- Power load terminals 6 to 12 AWG
 - Tightening torque: 30 in.-lbs

Universal Input

- Thermocouple, grounded or ungrounded sensors
 - >20MΩ input impedance
 - Maximum of 20Ω source resistance
- RTD 2- or 3-wire, platinum, 100Ω and 1000Ω @ 0°C calibration to DIN curve (0.00385 Ω/Ω/°C)
- Process, 0-20mA @ 100Ω, or 0-10V=(dc) @ 20kΩ input impedance; scalable, 0-50mV
- Inverse scaling

Digital Input

- Update rate 1Hz
- Dry contact or dc voltage

DC voltage

- Maximum input 36V at 3mA
 - Minimum high state 3V at 0.25mA
 - Maximum low state 2V
- Dry contact
- Maximum short circuit 13mA
 - Minimum open resistance 500Ω
 - Maximum closed resistance 100Ω

Current Measurement

- Accuracy ±15 percent of displayed value
- Accuracy range 5 to 50A
- Operating range 2 to 50A

Digital Output

- Update rate 1Hz
- Output voltage 24V, current limit 10mA

Allowable Operating Range

- Type J: 0 to 815°C or 32 to 1500°F
- Type K: -200 to 1370°C or -328 to 2500°F
- Type T: -200 to 400°C or -328 to 750°F
- Type N: 0 to 1300°C or 32 to 2372°F
- Type E: -200 to 800°C or -328 to 1470°F
- Type C: 0 to 2315°C or 32 to 4200°F
- Type D: 0 to 2315°C or 32 to 4200°F
- Type F: 0 to 1395°C or 32 to 2543°F
- Type R: 0 to 1760°C or 32 to 3200°F
- Type S: 0 to 1760°C or 32 to 3200°F
- Type B: 0 to 1816°C or 32 to 3300°F
- RTD (DIN): -200 to 800°C or -328 to 1472°F
- Process: -1999 to 9999 units

Output Hardware

- User selectable for heat/cool as on-off, P, PI, PD, PID, or alarm action. Not valid for limit controls
- Electromechanical relay, Form A, rated 2A
- SSR drive 20-28V=(dc) low side open collector switch
- SSR, Form A, 0.5A @ 24V~(ac) minimum, 264V~(ac) maximum, opto-isolated, without contact suppression
- Electromechanical relay, Form A, rated 5A, auxiliary output on PID module, output 2
- Electromechanical relay, Form C, rated 5A, auxiliary output on limit module, output 3

Specifications for Basic Remote User Interface (RUI)

Operator Interface

- Dual 4 digit, 7 segment LED displays
- Forward, backward, up and down keys plus a customer programmable function key
- Typical display update rate 1Hz
- Agency approved to IP65/NEMA 4X

Line Voltage/Power

- 100 to 240V~(ac), +10/-15 percent; (85-264V~[ac]) 50/60Hz, ±5 percent
- 24V=(ac/dc), +10/-15 percent; 50/60Hz, ±5 percent

Specifications for Mechanical Contactor

- Insulation class: UL® class B 130°C (266°F)
- Minimum load of 100 watts
- Duty cycle: continuous

Contact Ratings

Full Load Amps	Number of Poles	Line Voltage	Locked Rotor Amps	Resistive Amp Rating	Maximum Horsepower	
					Voltage	Single Phase
40	2	240/277	240	50	120	2
		480	200	50	240	3
		600	160	50		

EZ-ZONE ST With Definite Purpose Mechanical Contactor—Dimensional Drawings

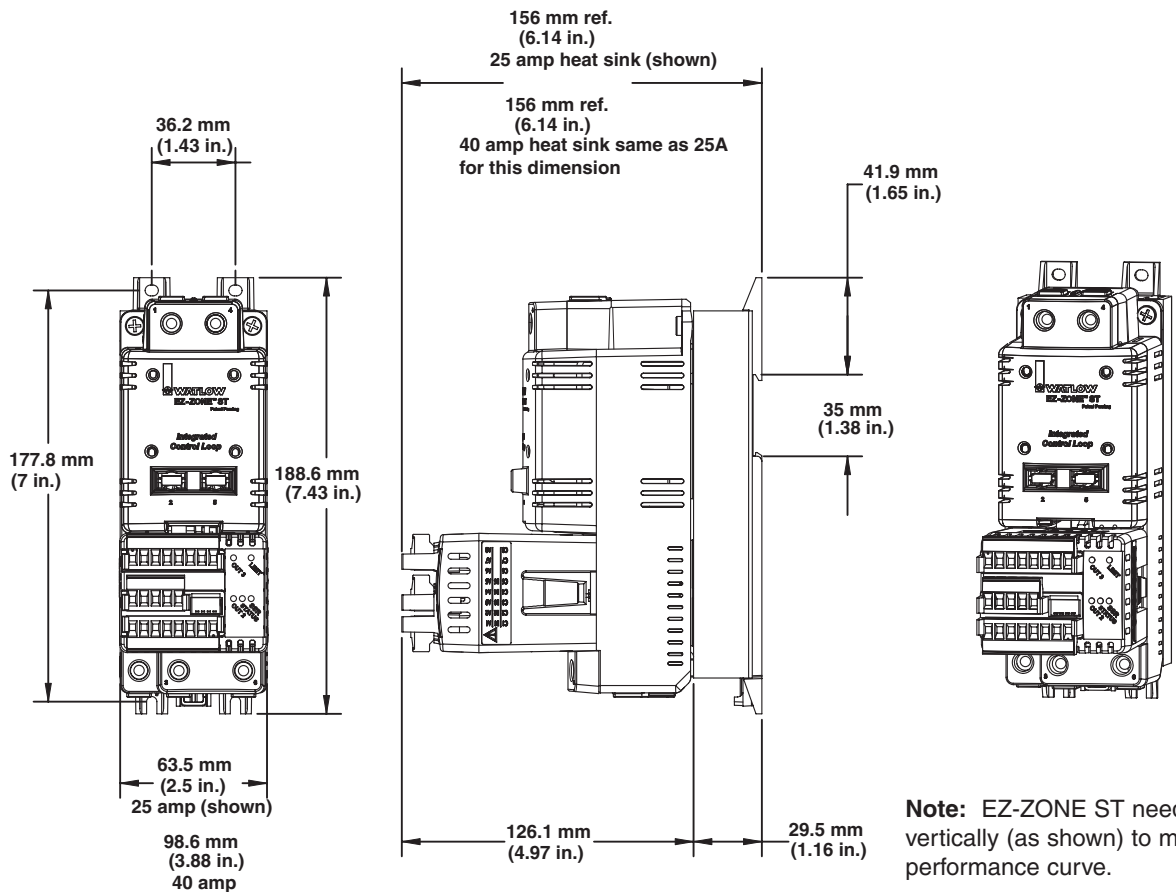

EZ-ZONE ST Without Definite Purpose Mechanical Contactor—Dimensional Drawings

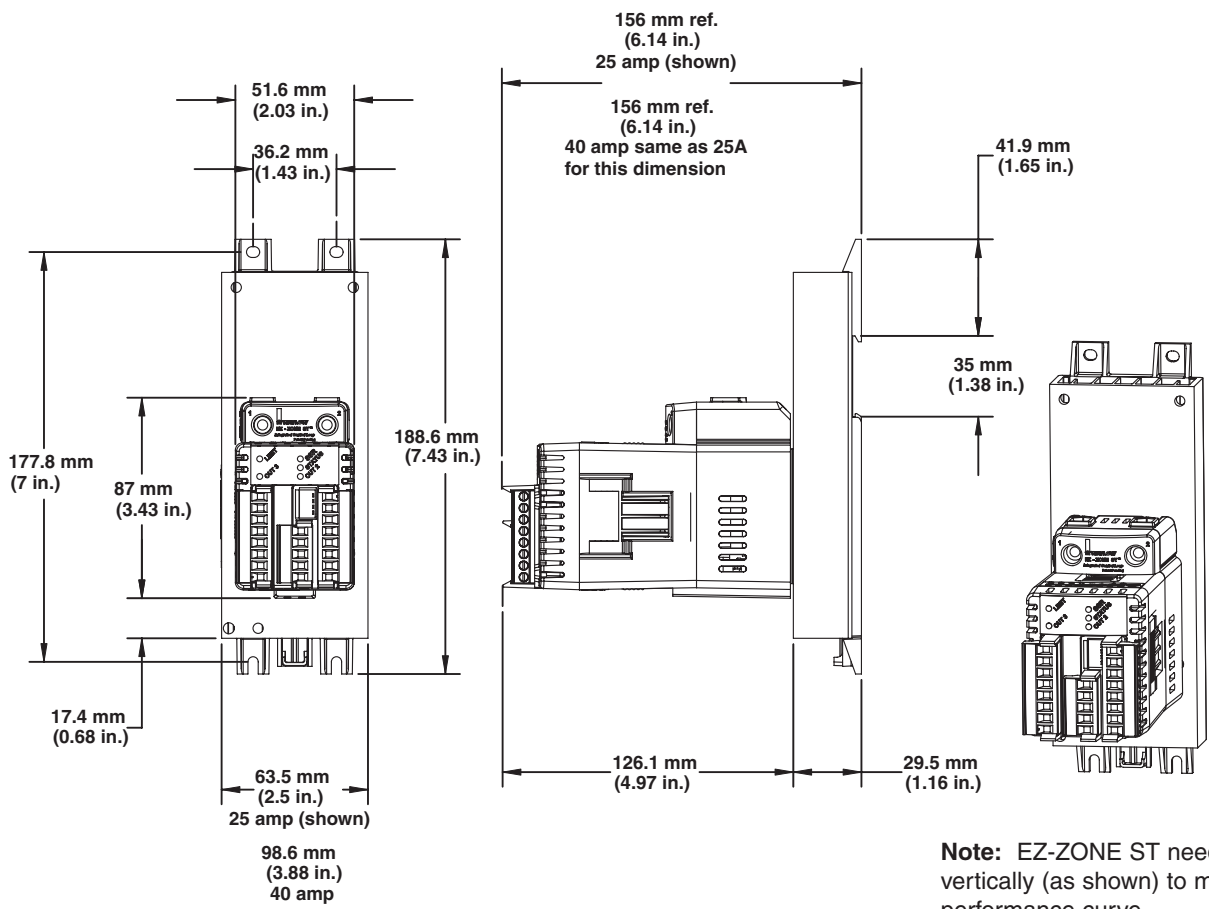

EZ-ZONE ST Solid State Relay With Heat Sink Specifications

Temperature and SSR Amperage Performance Curve
Watlow 25 and 40 Amp Solid State Relays

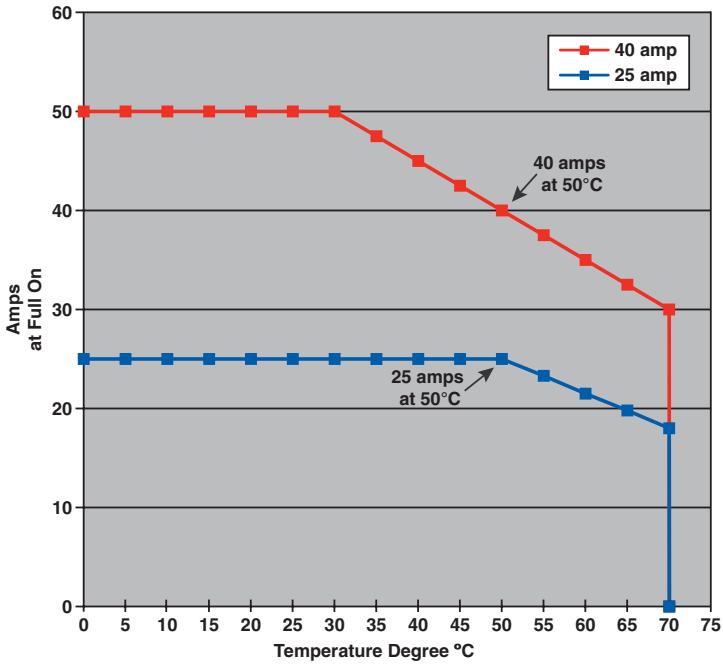

120/240V~(ac)		
Current output	25 amps	40 amps
Nominal voltage	120/240V~(ac)	120/240V~(ac)
One cycle surge current	600 amps	850 amps
Maximum I²t for fusing (A²s)	1500	3000
Thermo resistance	0.35° C/W	0.2° C/W
Base plate temperature	116°C	115°C
Voltage range	24 to 480	24 to 480
Over voltage rating	600V~(ac)	600V~(ac)
Off state leakage	1mA	1mA

480/600V~(ac)		
Current output	25 amps	40 amps
Nominal voltage	480V~(ac)	480V~(ac)
One cycle surge current	600 amps	850 amps
Maximum I²t for fusing (A²s)	1500	3000
Thermo resistance	0.35° C/W	0.2° C/W
Base plate temperature	116°C	115°C
Voltage range	48 to 660	48 to 660
Over voltage rating	1200V~(ac)	1200V~(ac)
Off state leakage	1mA	1mA

Input	
Voltage range	20 to 28V=(dc)

AC Output (Maximums)	
Forward voltage drop	1.3V
Minimum holding current	150mA
Turn on-off time	½ cycle
Frequency	47 to 63

Communications

Selecting the right communications ordering option for the EZ-ZONE ST:

Correct Ordering Option Letter	Connecting To	Another EZ-ZONE Product	RUI	Third Party Device (PLC, Touch Panel, etc.)
Option A*			Yes	
Option M**				Yes - Via Modbus™
Option A*		Yes	Yes	
Option M**		Yes		Yes - Via Modbus™

*A = Standard bus used to connect to Watlow PC software, RUI, other EZ-ZONES

**M = Modbus™ RTU (needed to communicate to third party devices) and standard bus. User selectable

Ordering Information

EZ-ZONE ST Integrated Control Loop

Code Number

ST = EZ-ZONE ST Integrated Control Loop

Integrated PID Controller

	Output 1*	Output 2	Total of 2 Digital I/O Points	Current Measurement
K =	SSR drive	0.5A SSR	No	No
B =	SSR drive	0.5A SSR	Yes	No
P =	SSR drive	0.5A SSR	No	Yes
E =	SSR drive	0.5A SSR	Yes	Yes
H =	SSR drive	5A mechanical relay	No	No
D =	SSR drive	5A mechanical relay	Yes	No
J =	SSR drive	5A mechanical relay	No	Yes
C =	SSR drive	5A mechanical relay	Yes	Yes

*Output 1 is dedicated to providing the command signal to the internal SSR.

Integrated Limit Controller

- A = None
- L = Limit control module with output 3, 5A Form C mechanical relay; with output 4, 2A Form A mechanical relay
- B = No limit control module but access to coil connection on mechanical contactor

Mechanical Contactor and Power Supply Options

- AH = No contactor and universal high voltage power supply 100-240V~(ac/dc)
- AL = No contactor and universal low voltage power supply 24-28V~(ac/dc)
- B1 = Single pole, 40A Watlow contactor, 24V~(ac) power supply
- B2 = Single pole, 40A Watlow contactor, 110/120V~(ac) power supply
- B3 = Single pole, 40A Watlow contactor, 208/240V~(ac) power supply
- F1 = Dual pole, 40A Watlow contactor, 24V~(ac) power supply
- F2 = Dual pole, 40A Watlow contactor, 110/120V~(ac) power supply
- F3 = Dual pole, 40A Watlow contactor, 208/240V~(ac) power supply

Communications

- A = Standard Bus used to connect to Watlow PC software, RUI, other EZ-ZONES
- M = Modbus™ RTU (needed to communicate to third party devices) and standard bus. User selectable

SSR

- B = 10A (24 to 240V~(ac) output)
- C = 25A (24 to 240V~(ac) output)
- D = 40A (24 to 240V~(ac) output)
- E** = 50A (24 to 240V~(ac) output)
- F** = 90A (24 to 240V~(ac) output)
- G = 25A (48 to 600V~(ac) output)
- H = 40A (48 to 600V~(ac) output)
- J** = 90A (48 to 600V~(ac) output)

** EZ-ZONE ST rated for maximum 40A @ 50°C

Heat Sinks

- A = None
- B = 25A
- C = 40A

Firmware

- A = Standard Watlow
- P = Profile ramp and soak (40 total steps, 1 to 4 profiles total)
- S = Custom

Customization (logo, parameters, hardware, firmware)

- AA = Standard
- XX = Letters to be determined, consult factory

S T

- - - - -

Remote User Interface (RUI)— Dimensional Drawings

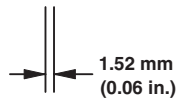
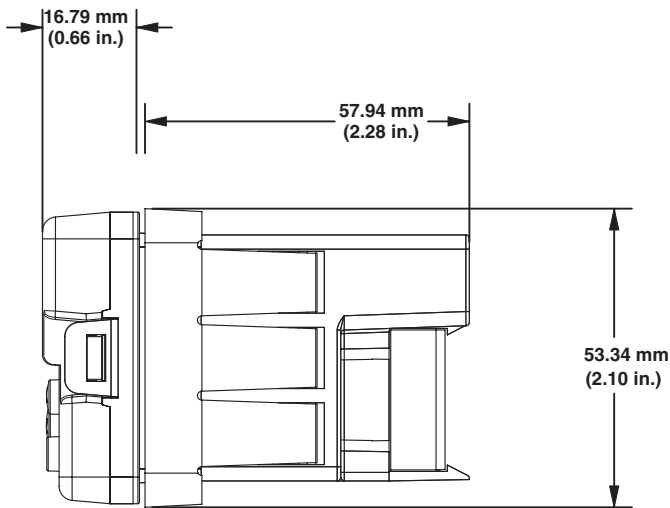
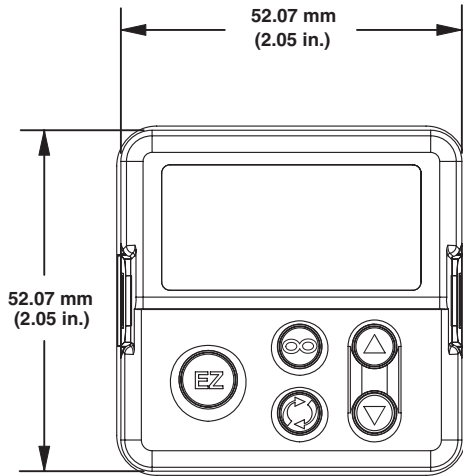

Ordering Information

EZ-ZONE ST Integrated Control Loop - Accessory Kit

Code Number

E Z K - - - - -

EZK = EZ-ZONE ST accessory kit

Remote User Interface (RUI)

A = None

B = Basic 1/6 DIN

Power Supply Voltage for Remote User Interface (RUI)

A = None, if no RUI is being ordered

L = Low voltage 24-28V≈(ac/dc)

H = Universal high voltage 100-240V≈(ac/dc)

Future Use

A = None

Custom Remote User Interface (RUI)

AA = None

XX = Custom options, consult factory

Future Use

A = None

Future Use

A = None

PC Based Software^①

AA = None

^① Configurator PC software is available for free, download at www.watlow.com.

Your Authorized Watlow Distributor Is:

To be automatically connected to the nearest North American Technical and Sales Office call:

1-800-WATLOW2

International Technical and Sales Offices: Australia, +61-3-9335-6449 • China, +86-21-3950-9510 • France, +33 (01) 3073-2425 • Germany, +49 (0) 7253-9400-0 • Italy, +39 (02) 458-8841 • Japan, +81-3-3518-6630 • Korea, +82-2-575-9804 • Malaysia, +60-3-7980-7741 • Mexico +52 (442) 217-6235 • Singapore, +65-6777-1266 • Spain, +34 916 751 292 • Sweden, +46 31 7014959 • Taiwan, +886-7-288-5168 • United Kingdom, +44 (0) 115-964-0777