

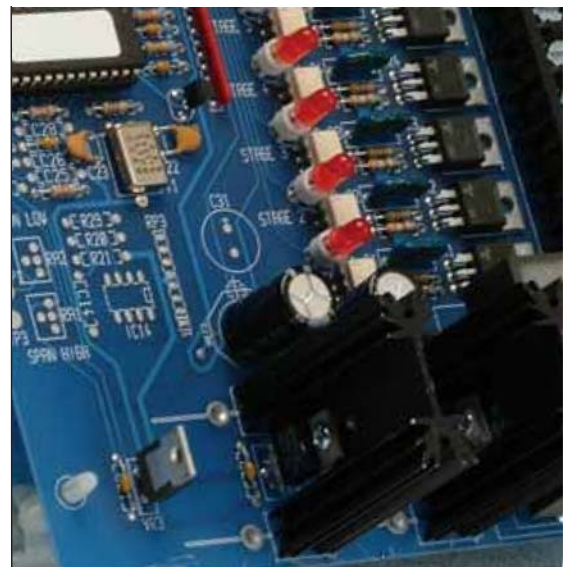

Control Products

Our products do more in a wide range of applications. **Expect More.**

- Zero-cross fired, proportional control
 - Rated up to 600VAC, single phase or three phase
 - A&B Series = up to 50 amps, M&S Series = up to 70 amps
 - Master and slave units can be combined for higher amperages
 - Standard inputs: 2200 ohms, 135 ohms, 4-20mA, 0-10VDC
 - Heatsinks and inputs electrically isolated from high voltage
 - UL Recognized, 122°F ambient with no derating required
 - Multiple mountings available, including weatherproof and NEMA 4X
-
- Microprocessor-based, field-programmable units
 - Programmable time delay, switching scheme and control type
 - Vernier control for improved performance over simple on/off controls
 - S95 Series = up to 20 stages, 208 Series = up to 4 stages
 - Pilot duty triacs are used as outputs to extend the contactors' life
 - UL Recognized, 167°F ambient with no derating required
 - Multiple mountings available, including a NEMA 1 enclosure



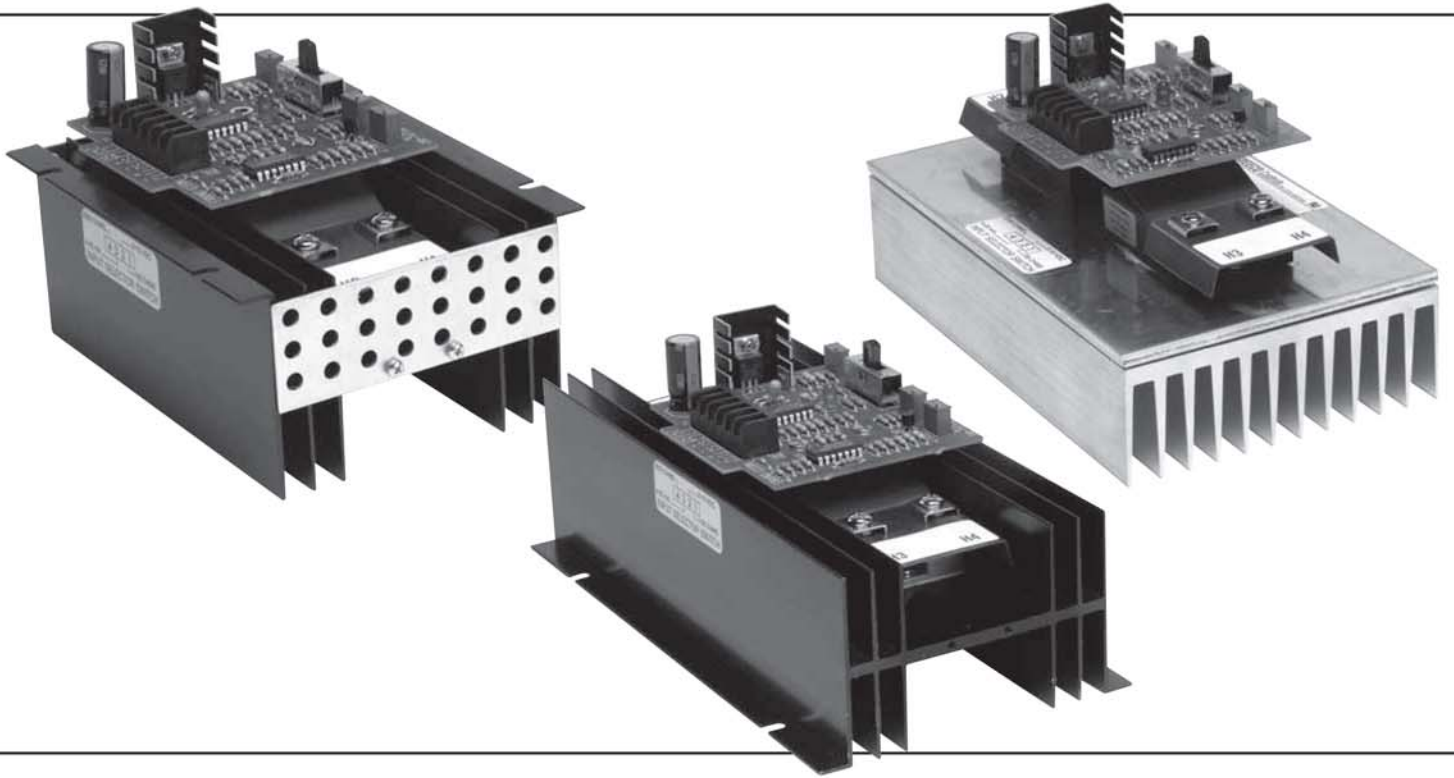

- HVAC Equipment
- Drying Equipment
- Industrial Ovens
- Industrial Heating Equipment

- Duct Heaters
- Air Curtains
- Process Air Heaters
- Immersion Heaters



Mounting & Series	Type	Max Voltage	Max Current	Input Code
101 = through panel	A1 = master, 1 phase	240 = 240VAC	20 = 20 amps	A = 2200 ohm
102 = inside panel	A3 = master, 3 phase	480 = 480VAC	30 = 30 amps	C = 135 ohm
103 = through panel	B1 = slave, 1 phase	600 = 600VAC	40 = 40 amps	E = 4-20mA
	B3 = slave, 3 phase		50 = 50 amps	L = 0-10VDC
				(blank) = slave





NEMA 4X rating available with the optional gasket kit. This saves space and reduces the panel size while adding little heat to the panel interior. There are no fans nor filter to maintain.



- Drying Equipment
- Industrial Ovens
- Industrial Heating Equipment

- Process Air Heaters
- Immersion Heaters
- Cartridge Heaters



Mounting	Type	AC Phase	AC Voltage	Max Current	Input Code	Gasket Kit
101	M = master	1 = 1 phase	120 = 120VAC	50 = 50 amps	A = 2200 ohm	W = included
	S = slave	3 = 3 phase	208 = 208VAC	70 = 70 amps	C = 135 ohm	blank = (none)
			240 = 240VAC		D = 6-9VDC	
			277 = 277VAC		E = 4-20mA	
			480 = 480VAC		L = 0-10VDC	
			600 = 600VAC		(blank) = slave	

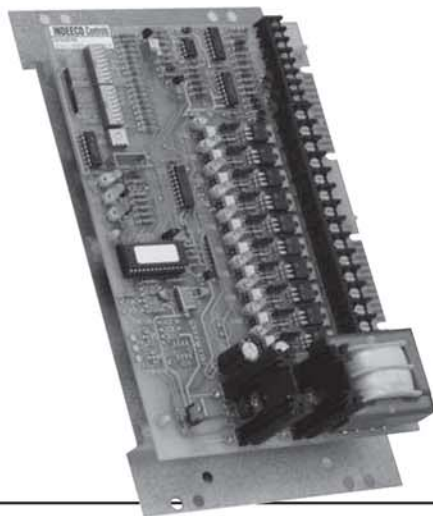

- Electric Boilers
- HVAC Equipment
- Drying Equipment
- Industrial Heating Equipment

- Immersion Heaters
- Duct Heaters
- Process Air Heaters
- Cartridge Heaters



Mounting & Series

201 - S95
204 - S95

Type

M = master
S = slave

Stages

05 = 5 stages
10 = 10 stages

Terminals

2 = terminal blocks

Input Code

A = 2200 ohm
C = 135 ohm
E = 4-20mA
L = 0-10VDC
V = adjustable VDC
(blank) = slave

Mounting & Series

205 - S95

Type

M = master

Stages

05 = 5 stages
10 = 10 stages

Terminals

2 = terminal blocks

Input Code

A = 2200 ohm

Temperature Range

21 = 0-100°F
43 = 50-180°F
47 = 100-210°F
51 = 120-250°F
55 = 150-250°F

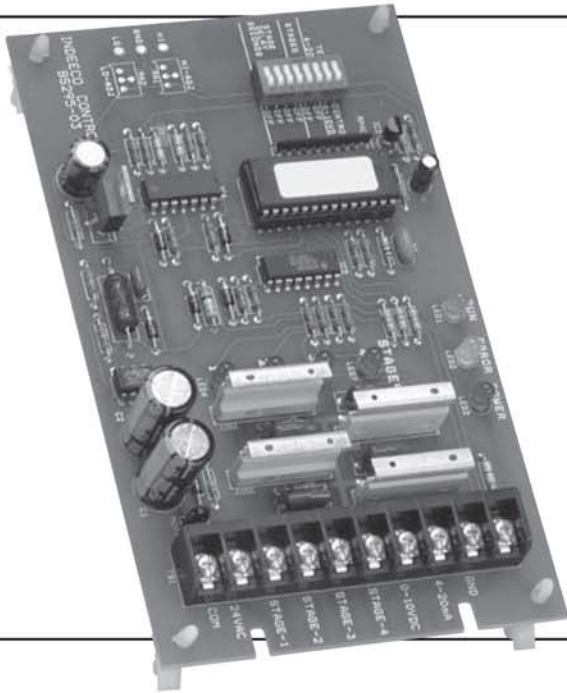

Low cost 24VAC control works with proportional thermostats, building management systems and other digital controls.



- HVAC Equipment
- Electric Boilers
- Drying Equipment
- Industrial Heating Equipment

- Duct Heaters
- Immersion Heaters
- Process Air Heaters
- Cartridge Heaters



Fixed 4-20mA & 0-10VDC inputs

Adjustable mA & VDC inputs



The 310 Thermistor Sensors must be wired in series with a 320 Setpoint Adjuster or 205 Step Control . The total resistance is 2200 ohms when the setpoint equals the sensor temperature. The NTC thermistor increases resistance as temperature decreases.

- A Series master
- M Series master
- S95 Series master

- B Series or S Series slaves
- S95 Series slave or 208 Series
- TempTimer Controls

Series	Probe Type & Availability	Temperature	Material	Length	Diameter
310-10	10 = air probe with flange (stainless steel only)	21 = 0-100°F	C = copper	03 = 3.0"	B = 0.275" typical
		41 = 50-150°F	S = 304	06 = 6.0"	
	40 = 3/8" NPT immersion (all materials & lengths)	43 = 50-180°F	stainless steel		
		47 = 100-210°F			
	41 = 1/8" NPT immersion (3" lengths only)	51 = 120-250°F			
		55 = 150-250° F			

The 320 Setpoint Adjusters must be wired in series with a 310 Thermistor Sensor. The total resistance is 2200 ohms when the sensor temperature equals the setpoint. The 205 Series Step Control uses a version of the 320 Series Setpoint Adjusters



- A Series master
- M Series master
- S95 Series master

- B Series or S Series slaves
- S95 Series slave or 208 Series
- TempTimer Controls

Series	Plate Type	Temperature	
320-P2	10 = Std. 1-gang, metal 2.75" W x 4.50" H	21 = 0 - 100°F	47 = 100 - 210°F
	20 = Polycarbonate 3.0" square	41 = 50 - 150°F	51 = 120 - 250°F
		43 = 50 - 180°F	55 = 150 - 250°F

INDEECO Controls will modify the standard product line to provide unique performance. We specialize in assisting large and small OEMs with solving their control problems. Our ability to design, develop and manufacture electronic controls allows us to provide a quick and economical solution. Please take advantage of a modification listed below or allow us to create a unique solution for you.

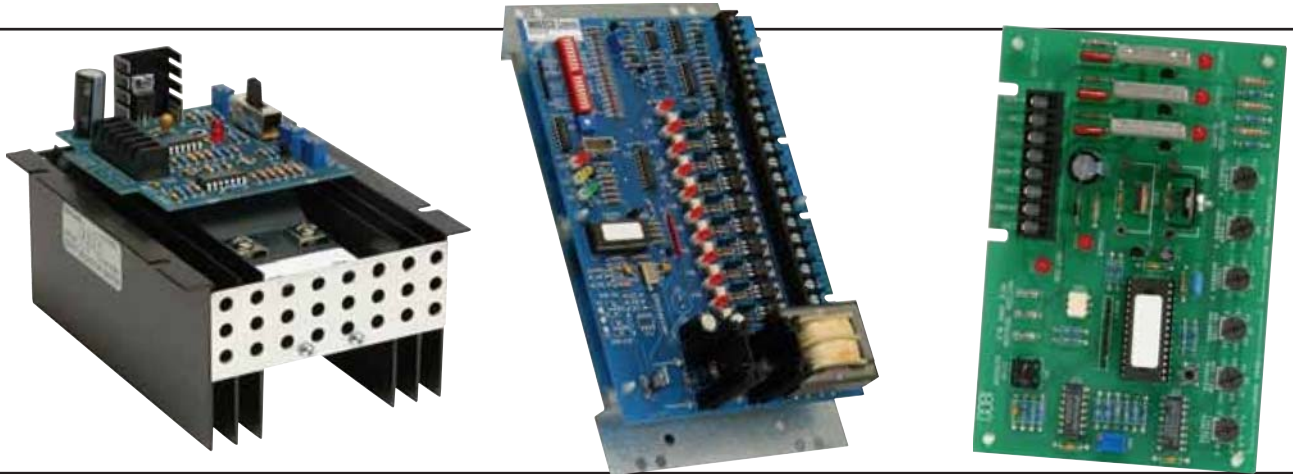

- NEMA 1 enclosures
 - Unique input ranges, such as 2-10VDC or 12-20mA
 - Thermistor input with a fixed, on-board setpoint
 - Thermocouple input with an adjustable on-board setpoint
 - Manual 0-100% potentiometer input
-
- Linear 0-10VDC vernier output instead of a pulsed-DC
 - Fixed or adjustable 0-20VDC input
 - Custom time delays
 - Reverse-acting control logic for chiller applications



We have the experience and expertise to provide you with the personalized support to arrive at customized solutions.

Contact: Power Modules Inc.
4 Raymond Drive Suite C
Havertown, PA 19083-1388
610-292-8900 Fax: 610-292-8898
info@pmiheat.com
www.pmiheat.com

When you need more than an off-the-shelf, standardized product. Ask **More.**

